

JUS SERIES HAZARDOUS LOCATION JUNCTION BOXES

Installation & Wiring Information

SAVE THESE INSTRUCTIONS FOR FUTURE REFERENCE

⚠ CAUTION Read carefully before installing and wiring. Any warning or special instructions should be closely followed. These instructions include information for installation in hazardous locations. Hazardous area installations should be done in accordance with article 500 and 501 of the NEC.

Check the ratings to insure suitability for the environment & supply. Must be installed in accordance with the NEC or CEC and all other applicable codes. All junction boxes must be properly grounded. Disconnect device from supply circuit before opening. Keep tightly closed when in operation. Do not attempt to install this device unless you are familiar with warnings, cautions and procedures outlined in this information sheet.

INSTALLATION & ELECTRICAL WIRING

⚠ WARNING Risk of electrical shock hazard, only qualified personnel should conduct this procedure! Do not make electrical connections with the power ON. Apply lubricant to all screws and threads during installation, failure to use can result in voiding warranty. Optional Terminal block: #10-22 AWG, cu or cu clad wire, rated 600V, max. 35 amps.

⚠ WARNING USE IN CLASS I DIV.2, GROUPS A,B,C & D; CLASS II DIV.2, GROUPS E, F & G; CLASS III, TYPE 4 ENCLOSURE.

1. Mount the junction box (0A) in its intended location using minimum 1/4" bolts (not provided). See illustration below for mounting dimensions.
 2. Cables should be stripped back approx. 3"- 5" to allow individual wires to flex.
 3. Install cable gland (not provided) to junction box (0A) per instructions furnished with cable gland.
 4. Route cable in through cable gland and secure seal on cable jacket.
 5. Make electrical connections.
 6. Connect Green or earth wire to green wire or ground screw (4B).
- NOTE:** Clean gasket surface free of debris prior to reassembly of cover. Verify that gasket cover (7A) was not damage and is in correct position.
7. Mount cover (1A) with #10 screws (9A) provided. Torque screws enough to insure a good gasket seal to approx. 20 in*lbs.

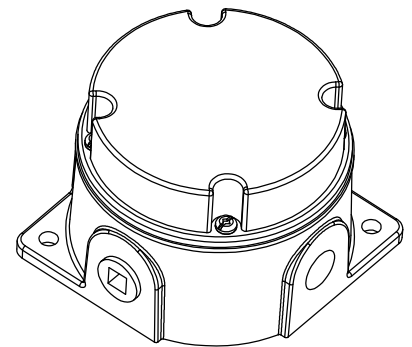
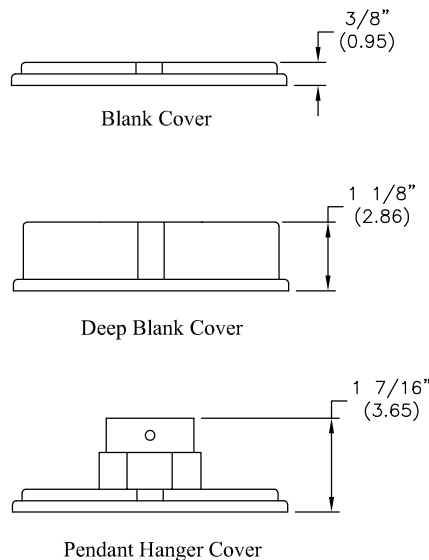
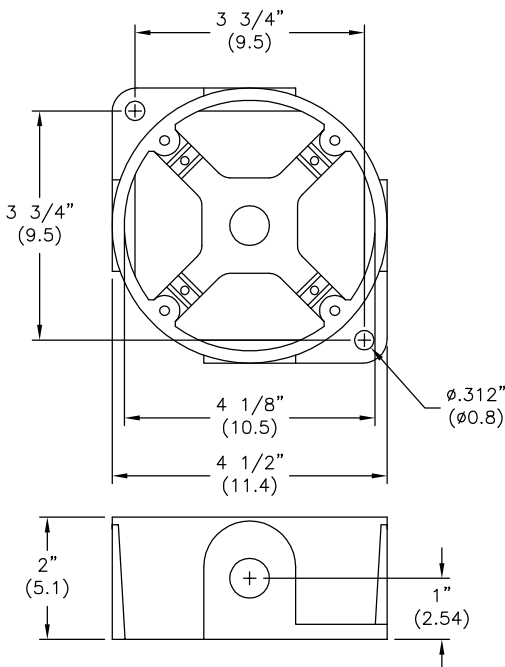
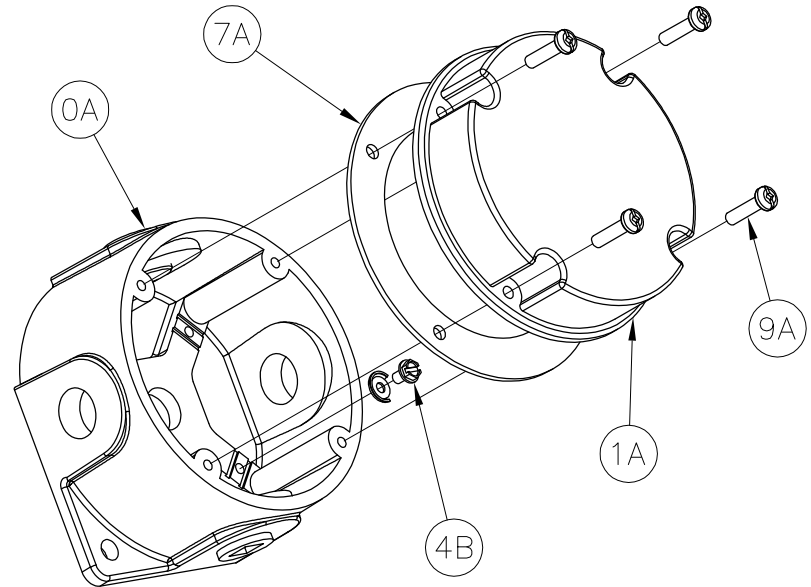

All statements, technical information and recommendations contained herein are based on information and tests we believe to be reliable. The accuracy or completeness thereof are not guaranteed. In accordance with Crouse-Hinds "Terms and Conditions of Sale", and since conditions of use are outside our control, the purchaser should determine the suitability of the product for his intended use and assumes all risk and liability whatsoever in connection therewith.